

KENWOOD

KNA-VC300

VOICE CONTROL MICROPHONE

INSTALLATION MANUAL

MICROPHONE DE COMMANDE VOCALE

MANUEL D'INSTALLATION

SPRACHSTEUERUNGSMIKROFON

INSTALLATION-HANDBUCH

SPRAAKSTURINGSMICROFOON

INSTALLATIE HANDLEIDING

MICROFONO DI CONTROLLO DELLA VOCE

MANUALE DI INSTALLAZIONE

MICRÓFONO DE CONTROL POR VOZ

MANUAL DE INSTALACIÓN

KENWOOD CORPORATION

KENWOOD

⚠ WARNING

- If repairs should be necessary, consult your Kenwood dealer.
- Please install the voice control microphone, the talk switch, and the necessary wiring in such a way that they will not hinder driving of the vehicle.
- When connecting, fix the cable of Voice Control Microphone using the component such as a clammer not to disturb your safe drive.

NOTE

Please refer to the navigation system's instruction manual for details regarding usage of the voice control microphone.

⚠ AVERTISSEMENT

- Si une réparation quelconque est nécessaire, consultez votre agent Kenwood.
- Veuillez installer le microphone de commande vocale, le commutateur de commande du microphone et le câblage nécessaire de façon à ce qu'il n'y ne présentent aucune interférence avec la conduite du véhicule.
- Lors de la connexion, fixez le câble du microphone de commande vocale par exemple à l'aide d'un attache-fils afin de ne pas perturber la conduite du véhicule.

REMARQUE

Veillez-vous référer au manuel d'utilisation du système de navigation pour les détails concernant l'utilisation du microphone de commande vocale.

⚠ WARNING

- Sollten Reparaturen erforderlich sein, wenden Sie sich an Ihren Kenwood-Händler.
- Montieren Sie bitte das Sprachsteuerungsmikrofon und den Sprechschalter so, dass die Fahrsicherheit nicht beeinträchtigt wird.
- Befestigen Sie das Kabel des Sprachsteuerungs-Mikrofons beim Anschluss unter Verwendung einer Komponente wie beispielsweise einer Klammer, damit Ihre Fahrt nicht gestört wird.

ANMERKUNG

Einzelheiten über die Benutzung des Sprachsteuerungsmikrofons finden Sie im Bedienungshandbuch des Navigationssystems.

⚠ WAARSCHUWING

- Neem voor reparaties contact op met uw Kenwood-dealer.
- Installeer de spraaksturingmicrofoon, de spreekschakelaar en de vereiste bedrading zodanig dat zij niet in de weg staan.
- Zet bij het aansluiten de kabel van de stemcontrolemicrofoon vast met een kabelklem of iets dergelijks, zodat hij niet kan hinderen tijdens het rijden.

OPMERKING

Zie de handleiding van het navigatiesysteem voor meer informatie over het gebruik van de spraaksturingmicrofoon.

⚠ AVVERTENZA

- Se è necessario effettuare delle riparazioni, rivolgersi al rivenditore Kenwood.
- Installare il microfono di controllo delle voci, l'interruttore di voce e il cablaggio necessario in modo tale da non ostruire la guida del veicolo.
- Quando collegate, fissate il cavo del microfono di controllo della voce utilizzando un componente tipo a morsetto per non disturbarvi da una guida sicura.

NOTA

Fate riferimento al manuale delle istruzioni del sistema di navigazione per ulteriori informazioni sull'uso del microfono di controllo delle voci.

⚠ ADVERTENCIA

- Si fuera necesaria una reparación, consulte a su distribuidor Kenwood.
- Instale el micrófono de control por voz, el interruptor de voz y el cableado necesario de modo tal que no interfieran con la conducción del vehículo.
- Cuando realice la conexión, fije el cable del micrófono de control de voz utilizando un accesorio tal como un fijador para no perturbarlo mientras conduce.

NOTA

Consulte el manual de instrucciones del sistema de navegación respecto de los detalles de uso del micrófono de control por voz.

Connection

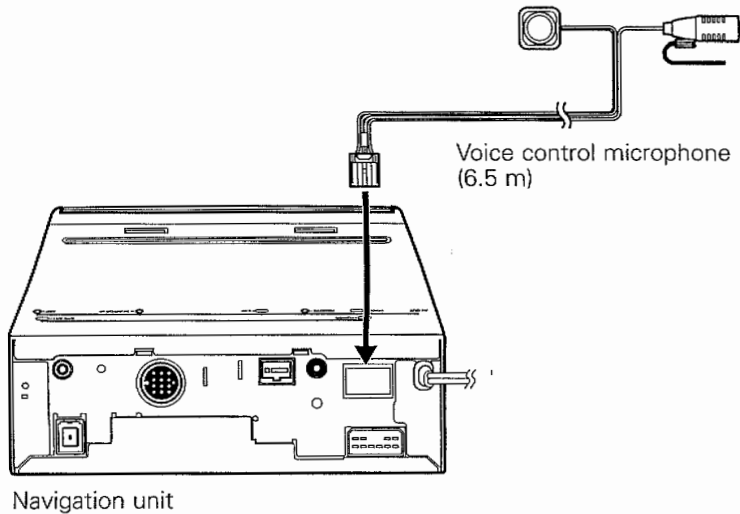

Installation

Talk Button Mounting

Remove the backing paper from the double-sided sticking tape on the talk button's rear surface, and then secure this switch in a location where it will not hinder operation of the vehicle.

 Positioning this component, as failure to do so will impair the tape's ability to stick securely.

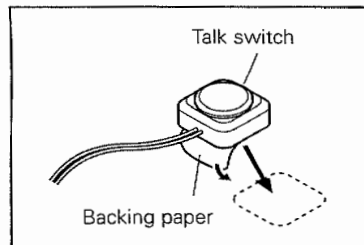

Microphone Mounting

The microphone should be mounted on the steering post or at some other location where it may clearly pickup the driver's voice.

-  • This microphone has directional characteristics: Please ensure that the microphone surface is facing the driver.
- In order to ensure good voice recognition, please ensure that the holes on the sides of the microphone are not covered in the installation position.
- Please avoid installation of the microphone in the vicinity of air-conditioner vents or in locations that are exposed to air blown in from the windows.
- The microphone should be located between 20 and 40 cm (8 and 16 in.) from the position of the driver's mouth.

- 1 Remove the backing paper from the double-sided sticking tape on the microphone clip's rear surface, and then secure this clip on the steering post or at some other location where it will not hinder operation of the vehicle.

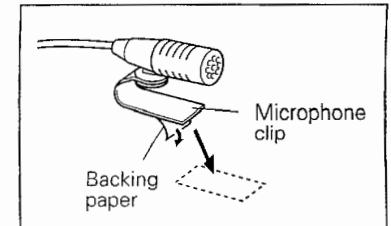

- 2 Adjust the horizontal orientation of the microphone in such a way that it faces towards the driver.

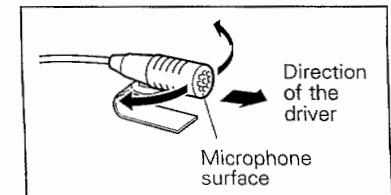

- 3 Position the microphone cord.

-  Be sure to remove any grease or dirt from the mounting surface before positioning this component as failure to do so will impair the tape's ability to stick securely.

